



INSTRUCTIONS AND PARTS LIST

This instruction manual contains IMPORTANT WARNINGS AND INSTRUCTION THAT MUST BE READ BEFORE OPERATING THE PUMP

HYDRAULIC
RATIO 5:1

MODEL BUD 5BBL

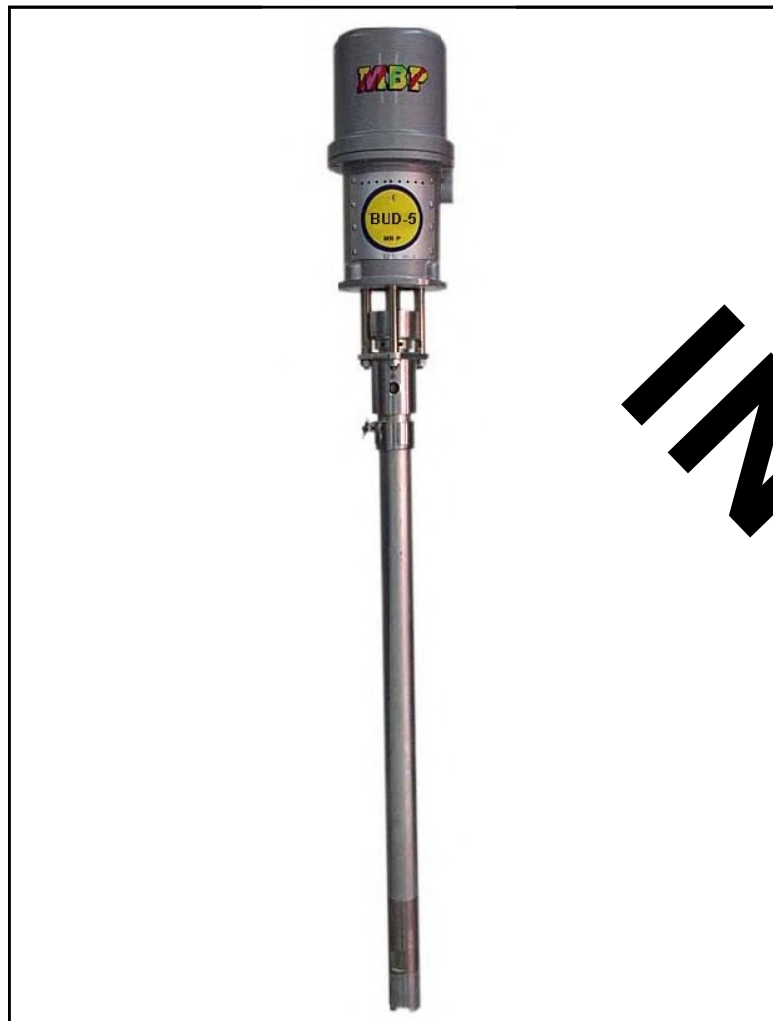

INDEX:

WARNINGS	2
TYPICAL INSTALLATION	3
PRESSURE RELIEF PROCEDURE	3
HOSE SAFETY	3
SPRAY GUN & OPERATING INSTRUCTIONS	3
MAINTENANCE (CLEANING AND FLUSHING)	3
SPRAY TIPS	4
PARTS DRAWING AND LIST	4, 5 & 6
TROUBLESHOOTING GUIDE	7
TECHNICAL DATA	7
STANDARD SPRAY TIPS	7
WARRANTY	8

WARNING

ATTENTION!! Read and understand all instructions carefully before operating equipment.

INJECTION HAZARD

This equipment generates very high fluid pressure. Spray from the gun, leaks or ruptured components can inject fluid through your skin and into your body and cause extremely serious bodily injury.

The spray gun should never be handled carelessly, nor spray directed toward any part of the body. Keep your hands and fingers away from spray gun nozzle.

Be sure equipment safety devices are operating properly before each use.

If any fluid appears to penetrate your skin, get emergency medical care at once. Do not treat as a simple cut. Tell the doctor exactly what fluid was injected.

FIRE HAZARD

Static electricity is created by the high velocity flow of fluid through the pump and hose. If every part of spray equipment is not properly grounded, sparking immediately. Check the entire system for positive grounding.

GROUNDING

Before starting to work the pump must be connected to ground:

- 1.- The pump must be connected to ground with a ground wire which is supplied with the pump (4 mm² of section and a clamp). See connection on page 6.
- 2.- **SPRAY GUN:** Obtain grounding through connection to a properly grounded fluid hose and pump.
- 3.- **OBJECT BEING SPRAYED:** Use ground wire and clamp.
- 4.- **AIR COMPRESOR:** Follow air compressor manufacturer's recommendations.
- 5.- Use **ONLY METAL PAILS**, which are conductive. Do not place the pail on a non-conductive surface, such as paper or cardboard, which interrupts the grounding continuity.

TYPICAL INSTALLATION

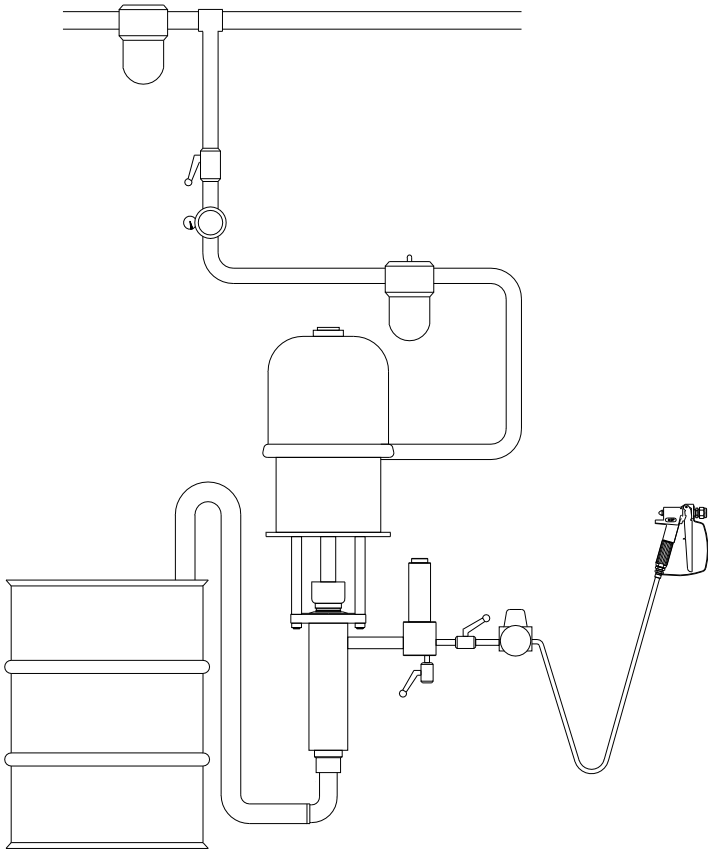

PRESSURE RELIEF PROCEDURE

- 1.- Engage the gun safety latch.
- 2.- Shut off the air to the pump.
- 3.- Close the air inlet valve.
- 4.- Disengage the gun safety latch.
- 5.- Hold a metal part of the gun firmly to the side of a grounded metal pail, and trigger the gun safety latch.
- 6.- Engage the gun safety latch.
- 7.- Open the drain valve, having a grounded metal container ready to catch the drainage.
- 8.- Leave the drain valve open until you are ready to spray again.

HOSE SAFETY

Tighten all fluid connections securely before each use. Never use a damaged hose. Before each use, check entire hose for cuts, leaks, abrasions, bulging cover, or damage or movement of the hose couplings. If any of these conditions exist, replace the hose immediately.

SPRAY GUN

It is recommended strain the fluid you are spraying if it contains particles which could clog the spray tip.

CLEANING THE SPRAY TIP

Clean off the front of the tip frequently during the day's operation and at the end of the work day. Always follow the Pressure Relief Procedure on page 3. Then use a solvent soaked brush to clean the spray tip and to keep fluid buildup from drying and clogging the spray tip.

If the spray tip clogs while spraying, release the spray gun trigger, engage the trigger safety, shut off the pump, and follow the Pressure Relief Procedure. Remove the spray tip and blow out the obstructions with air from the front of the spray tip.

Normal daily flushing of your spray system and gun flushes away most buildup on the filter. However, you should remove the filter frequently and clean it.

FLUSHING THE GUN

Relieve pressure, remove the spray tip, and then flush the gun and spray system with a compatible solvent. Always flush the gun before the fluid being sprayed can dry in it.

OPERATING INSTRUCTIONS

Follow all instructions above, be sure that fittings at pump outlet and at gun are tight. Use two wrench to tighten the main fitting. Do not install the spray tip at this time.

Fill the packing nut with oil to help prolong the packing life.

Put the suction tube into the paint container. Flush the pump with a compatible solvent before using it.

Open the air inlet valve. Disengage the gun safety and trigger the spray gun into a grounded metal pail, and slowly open the air supply valve until the pump starts (about 3 or 4 bar). The lines are purged when the fluid emitted from the gun is flowing in a steady stream. Engage the gun safety, shut off the air inlet valve then install the spray tip in the gun.

Open the air inlet valve. When the pump and the lines are primed, and adequate air pressure and volume are supplied, the pump will start and stop as the spray gun is triggered and released.

Disengage the gun safety and you are now ready to spray!!

MAINTENANCE (CLEANING AND FLUSHING)

It is recommended that at the end of each day, paint should be flushed from unit with compatible solvent then reflushed with mineral spirits.

- 1.- Engage the gun safety and follow the Pressure Relief Procedure.
- 2.- Remove the spray tip and clean with a compatible solvent and soft brush.
- 3.- Disengage the gun safety and follow the pressure relief procedure. Lift suction tube above paint level until tube is empty. Introducing the suction tube in a pail with compatible solvent. Disengage gun safety and trigger gun into the pail until it runs clear. Close the air inlet valve.
- 4.- Open the fluid drain valve. Remove the fluid filter and the gun filter and clean them with solvent.
- 5.- Flush the sprayer at the end of each work day and fill it with solvent to help prevent pump corrosion.

PARTS LIST

1.-	AIR MOTOR	A.100.00
2.-	TIE	C.100.01X
3.-	NUT	CTU.101
4.-	PIN	CPA.101
5.-	DISPLACEMENT PUMP	43.400.00
6.-	BUNG ADAPTER	4.500.00
7.-	FLUID FILTER	G500.00X

SPRAY TIPS

When a tip is the wrong size, or becomes the wrong size through wear, the spray pattern worsens, coverage decreases, you have less control over the desired rate of coverage, and it takes longer to finish the job. In the worst case, the pump supplying the tip can be damaged. Because most architectural coating are abrasive, tip wear can happend quite quickly. Notice as wear increases the orifice size, it decreases the fan width which greatly affects coverage rates.

If tip shows excessive wear, replace it to maximize productivity and save paint.

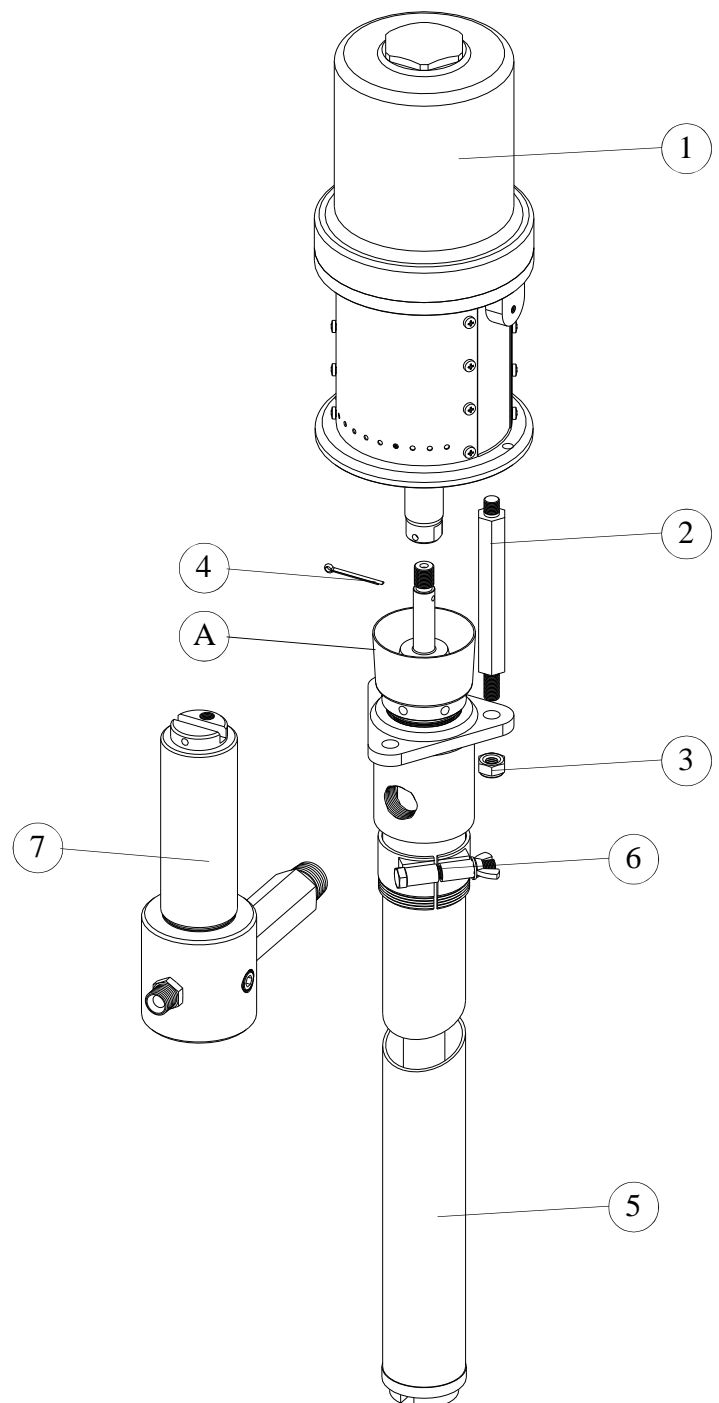

DISPLACEMENT PUMP

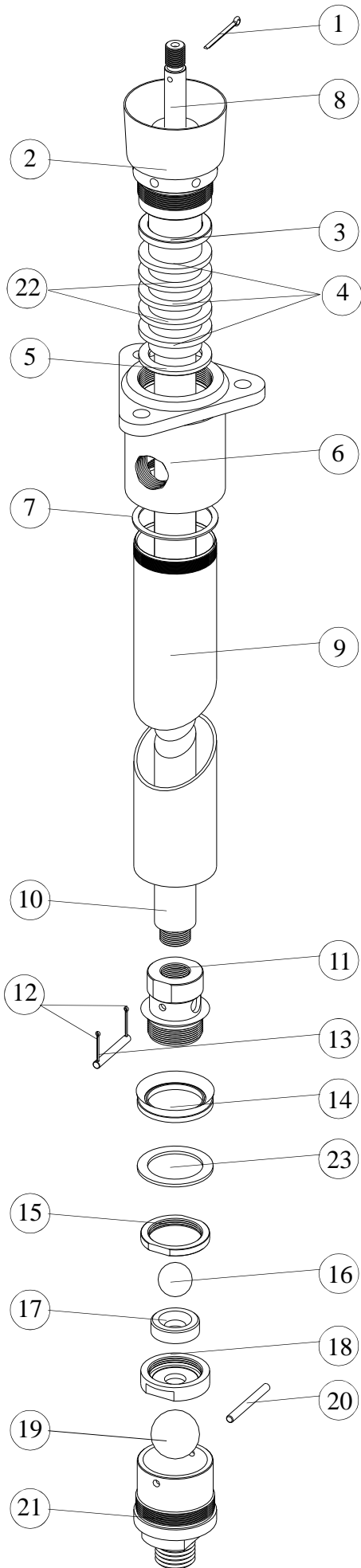

43.400.00

N°	REF.	DESCRIPTION	Q
1	C.PA1.01	PIN	1
2	B.220.00	PACKING NUT	1
*3	B.230.01	FEMALE GLAND	1
*4	B.230.02	PACKING	3
*5	B.230.03	MALE GLAND	1
6	43.410.00	HOUSING	1
7	43.400.01	JOINT	1
8	B.200.03	ROD	1
9	4.000.17X	SLEEVE	1
10	45.400.02X	ROD	1
11	B.240.01	PISTON	1
12	B.240.09	PIN	2
13	B.240.05	PIN	1
*14	43.420.01	PACKING	1
15	B.240.04	NUT	1
16	C.B01.03	BALL	1
17	B.240.06	SEAT	1
18	B.240.07	NUT	1
19	C.B01.15	BALL	1
20	3.400.02	PIN	1
21	3.400.01X	VALVE	1
*22	B.230.04	PACKING	2
23	B.240.03	SCRAPER	1

*** Included in KIT.036**

NOTE: Fix parts 10, 11, 15 and 18 with loctite 542 or similar (wait 1 hour before start running the unit)

AIR MOTOR

N°	REF.	DESCRIPTION	Q
1	A.110.02	CAP	1
2	CJT.001	JOINT	1
3	A.110.01	CYLINDER	1
4	A.120.04	ROD	2
5	A.120.07	SUPPORT	1
6	A.120.08	YOKE	1
7	A.121.00	ROD	1
8	CTH.008	SCREW	2
9	A.140.02	CLIP	2
10	A.140.01	PISTON	1
*11	A.122.00	STEM	2
*12	CJT.002	JOINT	1
13	A.120.11	ROD	1
*14	CJT.003	JOINT	1
15	CB2.015	SLEEVE	1
*16	CJT.004	JOINT	1
17	A.130.02	PLATE	2
18	A.150.01	BASE	1
19	CTA.001	SCREW	6
20	CTC.001	SCREW	16
21	A.120.01	ROCKER	2
22	A.120.02	SPRING	2
23	A.120.03	ROD	2
*24	A.120.05	CLIP	2
25	A.120.06	NUT	4
26	A.150.02	JOINT	1
*27	A.120.10	JOINT	2
*28	A.120.09	JOINT	2
29	CAR.125	RETAINER	1
30	TIE.GR	GROUND	1

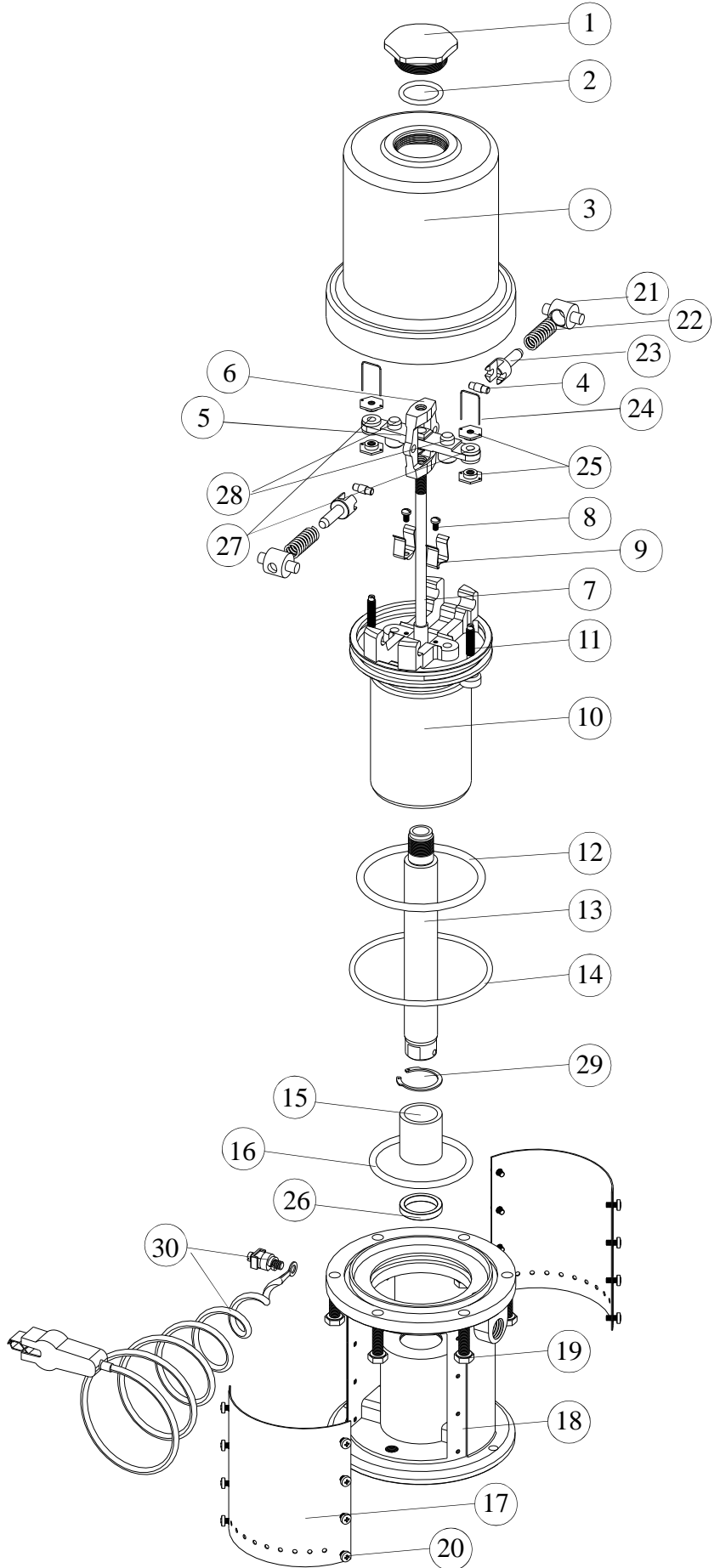

* Included in KIT.058

TROUBLESHOOTING GUIDE

PROBLEM	POSSIBLE CAUSE	SOLUTION
Pump fails to operate.	<ul style="list-style-type: none"> ■ Restricted line or inadequate air supply. ■ Insufficient air pressure, closed or clogged air valves, etc. ■ Exhausted fluid supply. ■ Obstructed fluid hose, gun or dispensing valve. ■ Clogged spray tip or filters. 	<ul style="list-style-type: none"> ■ Clear, increase air. ■ Open, clean. ■ Refill; purge all air from pump and fluid lines. ■ Clear. ■ Clear or replace.
Pump operates but output low on down stroke.	<ul style="list-style-type: none"> ■ Clogged filters. ■ Throat packings nut too tight or too loose. ■ Exhausted fluid supply. ■ Obstructed fluid hose or gun. ■ Worn spray tip. ■ Held open or worn intake valve. ■ Held open or worn fluid piston or packings. 	<ul style="list-style-type: none"> ■ Clear or replace. ■ Adjust. ■ Refill and prime. ■ Clear. ■ Replace. ■ Clear. ■ Clear or replace.
Erratic or accelerated operating.	<ul style="list-style-type: none"> ■ Exhausted fluid supply. ■ Check valves need adjustment. ■ Held open or worn intake valve. ■ Held open or worn fluid piston or packings. 	<ul style="list-style-type: none"> ■ Refill and prime. ■ Adjust. ■ Clear. ■ Clear or replace.

For trouble free operation is absolutely essential that your sprayer be kept clean and free of residual paint build-up on the internal parts. It must be cleaned and lubricated after each use.

TECHNICAL DATA

PUMPRATIO: 5:1.

RECOMMENDED MAXIMUM AIR SPEED: 60 CYCLES/MIN.

RECOMMENDED AIR PRESSURE: FROM 2 TO 8 BAR.

FLOW AT 60 CYCLES/MIN.: 9 LITRES/MIN.

MAXIMUM WORKING PRESSURE: 62 BAR.

STANDARD SPRAY TIPS

ORIFICE SIZE MM / INCHES	FLOW IN LITRES / MIN	FAN WIDTH AT 300 MM.	ORIFICE SIZE MM / INCHES	FLOW IN LITRES / MIN	FAN WIDTH AT 300 MM.
0.23 MM. .009" 9.20 9.40 9.60	0.30	100-150 200-250 300-350	0.53 MM. .021" 21.20 21.40 21.60	1.74	100-150 200-250 300-350
0.28 MM. .011" 11.20 11.40 11.60	0.45	100-150 200-250 300-350	0.58 MM. .023" 23.20 23.40 23.60	2.08	100-150 200-250 300-350
0.33 MM. .013" 13.20 13.40 13.60	0.64	100-150 200-250 300-350	0.63 MM. .025" 25.20 25.40 25.60	2.49	100-150 200-250 300-350
0.38 MM. .015" 15.20 15.40 15.60	0.87	100-150 200-250 300-350	0.68 MM. .027" 27.20 27.40 27.60	2.91	100-150 200-250 300-350
0.43 MM. .017" 17.20 17.40 17.60	1.13	100-150 200-250 300-350	0.74 MM. .029" 29.20 29.40 29.60	3.33	100-150 200-250 300-350
0.48 MM. .019" 19.20 19.40 19.60	1.36	100-150 200-250 300-350	0.79 MM. .031" 31.20 31.40 31.60	3.86	100-150 200-250 300-350

WARRANTY

M.B.P., will any repairs necessary during the first 12 months after purchase of a new unit, with the exceptions shown under 1 and 2 below, and under the conditions shown in item 3.

- 1.- Damage caused by external abuse, customer negligence, or failure to operate the unit in accordance with the instructions supplied with the unit.
- 2.- Normal maintenance items.
- 3.- Within the first 12 months after purchase, M.B.P. will pay 100% of the cost of covered repairs.

In no case will M.B.P. liability extend beyond repair or replacement of the equipment. Such liability is limited to the amount of the original purchase price paid for the unit, minus a reasonable deduction for the time the unit has been in service. It is the responsibility of the purchaser under this warranty to ship or deliver the failed paint sprayer to the authorized service center at the purchaser's expense. Parts or components covered under this warranty may either be repaired or replaced at M.B.P. option.

Equipment not covered by M.B.P. warranty. Accessories or components of equipment sold by M.B.P. that are not manufactured by M.B.P. are subject to the warranty, if any, of their manufacturer. M.B.P. will provide purchaser with reasonable assistance in making such claims.

The Industry Department of The Basque Government, states that all electric and pneumatic airless equipment manufacture by M.B.P. S.L., follows the "CE" standards under the number 83/392/CEE.

DECLARACION DE CONFORMIDAD "CE" "EC" DECLARATION OF CONFORMITY

MODELO / MODEL BUD - 5L

Este producto cumple con la siguiente directiva de la Comunidad Europea.

This Product complies with the following European Community Directive.

Directiva 2014/34/EU Atex sobre máquinas. (Ex II 2G c T6 X)

Machinery Directive 2014/34/EU Atex Directive. (Ex II 2G c T6 X)

APROBADO POR /

APPROVED BY

AITOR ORTIZ

FECHA / DATE

MBP, S.L. figura inscrita en el Registro Industrial del País Vasco con el N° 01/8030 y cumple los requisitos para el desarrollo de su actividad comercial.

MBP, S.L. is registered in the Industrial Register of the Basque Country with the N° 01/8030.

