



INSTRUCTIONS AND PARTS LIST

This instruction manual contains IMPORTANT WARNINGS AND INSTRUCTION THAT MUST BE READ BEFORE OPERATING THE PUMP

HYDRAULIC RATIO 45:1

MODELS HD 45BS • HD 45CS



INOX

INDEX:

WARNINGS.....	2
TYPICAL INSTALLATION.....	3
PRESSURE RELIEF PROCEDURE.....	3
HOSE SAFETY.....	3
SPRAY GUN & OPERATING INSTRUCTIONS.....	3
MAINTENANCE (CLEANING AND FLUSHING).....	3
SPRAY TIPS.....	4
PARTS DRAWING AND LIST	4, 5 & 6
SERVICE HD-AIR MOTOR	7
DISPLACEMENT PUMP REPAIR	9
TROUBLESHOOTING GUIDE	11
TECHNICAL DATA	11
STANDARD SPRAY TIPS	11
WARRANTY.....	12

WARNING

ATTENTION!! Read and understand all instructions carefully before operating equipment.

INJECTION HAZARD

This equipment generates very high fluid pressure. Spray from the gun, leaks or ruptured components can inject fluid through your skin and into your body and cause extremely serious bodily injury.

The spray gun should never be handled carelessly, nor spray directed toward any part of the body. Keep your hands and fingers away from spray gun nozzle.

Be sure equipment safety devices are operating properly before each use.

If any fluid appears to penetrate your skin, get emergency medical care at once. Do not treat as a simple cut. Tell the doctor exactly what fluid was injected.

FIRE HAZARD

Static electricity is created by the high velocity flow of fluid through the pump and hose. If every part of spray equipment is not properly grounded, sparking immediately. Check the entire system for positive grounding.

GROUNDING

Before starting to work the pump must be connected to ground:

- 1.- The pump must be connected to ground with a ground wire which is supplied with the pump (4 mm² of section and a clamp). See connection on page 5.
- 2.- SPRAY GUN: Obtain grounding through connection to a properly grounded fluid hose and pump.
- 3.- OBJECT BEING SPRAYED: Use ground wire and clamp.
- 4.- AIR COMPRESOR: Follow air compressor manufacturer's recommendations.
- 5.- Use **ONLY METAL PAILS**, which are conductive. Do not place the pail on a non-conductive surface, such as paper or cardboard, which interrupts the grounding continuity.

TYPICAL INSTALLATION

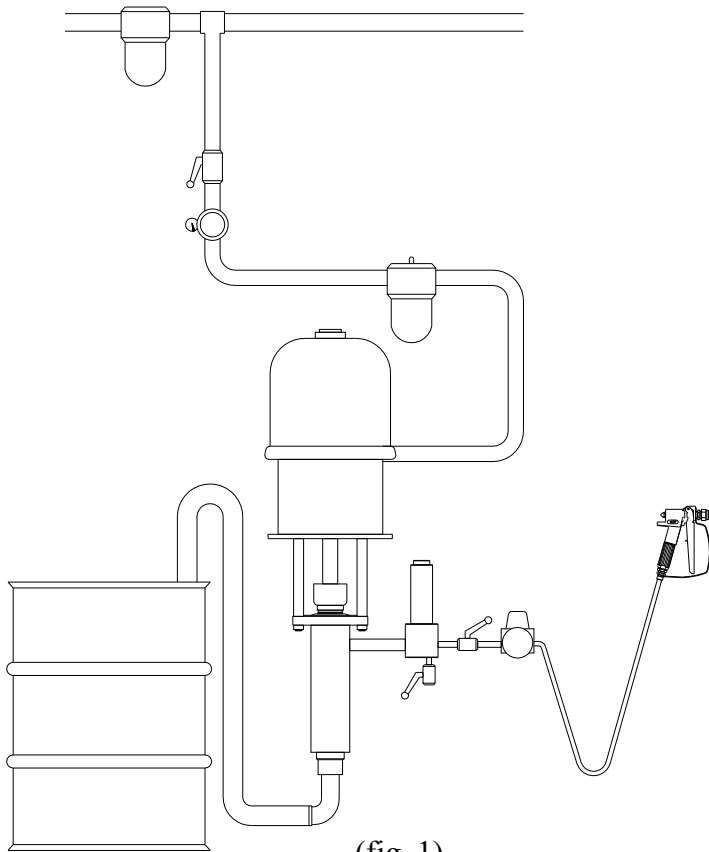

(fig. 1)

PRESSURE RELIEF PROCEDURE

- 1.- Engage the gun safety latch.
- 2.- Shut off the air to the pump.
- 3.- Close the air inlet valve.
- 4.- Disengage the gun safety latch.
- 5.- Hold a metal part of the gun firmly to the side of a grounded metal pail, and trigger the gun safety latch.
- 6.- Engage the gun safety latch.
- 7.- Open the drain valve, having a grounded metal container ready to catch the drainage.
- 8.- Leave the drain valve open until you are ready to spray again.

HOSE SAFETY

Tighten all fluid connections securely before each use. Never use a damaged hose. Before each use, check entire hose for cuts, leaks, abrasions, bulging cover, or damage or movement of the hose couplings. If any of these conditions exist, replace the hose immediately.

SPRAY GUN

It is recommended strain the fluid you are spraying if it contains particles which could clog the spray tip.

CLEANING THE SPRAY TIP

Clean off the front of the tip frequently during the day's operation and at the end of the work day. Always follow the Pressure Relief Procedure on page 3. Then use a solvent soaked brush to clean the spray tip and to keep fluid buildup from drying and clogging the spray tip.

If the spray tip clogs while spraying, release the spray gun trigger, engage the trigger safety, shut off the pump, and follow the Pressure Relief Procedure. Remove the spray tip and blow out the obstructions with air from the front of the spray tip.

Normal daily flushing of your spray system and gun flushes away most buildup on the filter. However, you should remove the filter frequently and clean it.

FLUSHING THE GUN

Relieve pressure, remove the spray tip, and then flush the gun and spray system with a compatible solvent. Always flush the gun before the fluid being sprayed can dry in it.

OPERATING INSTRUCTIONS

Follow all instructions above, be sure that fittings at pump outlet and at gun are tight. Use two wrench to tighten the main fitting. Do not install the spray tip at this time.

Fill the packing nut with oil to help prolong the packing life.

Put the suction tube into the paint container. Flush the pump with a compatible solvent before using it.

Open the air inlet valve. Disengage the gun safety and trigger the spray gun into a grounded metal pail, and slowly open the air supply valve until the pump starts (about 3 or 4 bar). The lines are purged when the fluid emitted from the gun is flowing in a steady stream. Engage the gun safety, shut off the air inlet valve then install the spray tip in the gun.

Open the air inlet valve. When the pump and the lines are primed, and adequate air pressure and volume are supplied, the pump will start and stop as the spray gun is triggered and released.

Disengage the gun safety and you are now ready to spray!!

MAINTENANCE (CLEANING AND FLUSHING)

It is recommended that at the end of each day, paint should be flushed from unit with compatible solvent then refushed with mineral spirits.

- 1.- Engage the gun safety and follow the Pressure Relief Procedure.
- 2.- Remove the spray tip and clean with a compatible solvent and soft brush.
- 3.- Disengage the gun safety and follow the pressure relief procedure. Lift suction tube above paint level until tube is empty.
Introducing the suction tube in a pail with compatible solvent. Disengage gun safety and trigger gun into the pail until it runs clear. Close the air inlet valve.
- 4.- Open the fluid drain valve. Remove the fluid filter and the gun filter and clean them with solvent.
- 5.- Flush the sprayer at the end of each work day and fill it with solvent to help prevent pump corrosion.

AIR MOTOR

N°	REF.	DESCRIPTION	Q
1	A.421.00	PISTON	1
2	CJT.018	O-RING	1
3	A.422.00	SHAFT	1
4	A.420.01	CONNECTOR	1
5	CAB.008	PACKING	1
6	A.430.03	JOINT	2
7	A.400.03	JOINT	1
8	CJT.019	O-RING	1
9	CB2.009	SLEEVE	1
10	CB2.010	SLEEVE	1
11	A.430.01	MOTOR BODY	1
12	A.430.02	JOINT	1
13	CTT.008	SCREW	12

SPRAY TIPS

When a tip is the wrong size, or becomes the wrong size through wear, the spray pattern worsens, coverage decreases, you have less control over the desired rate of coverage, and it takes longer to finish the job. In the worst case, the pump supplying the tip can be damaged. Because most architectural coating are abrasive, tip wear can happend quite quickly. Notice as wear increases the orifice size, it decreases the fan width which greatly affects coverage rates.

If tip shows excessive wear, replace it to maximize productivity and save paint.

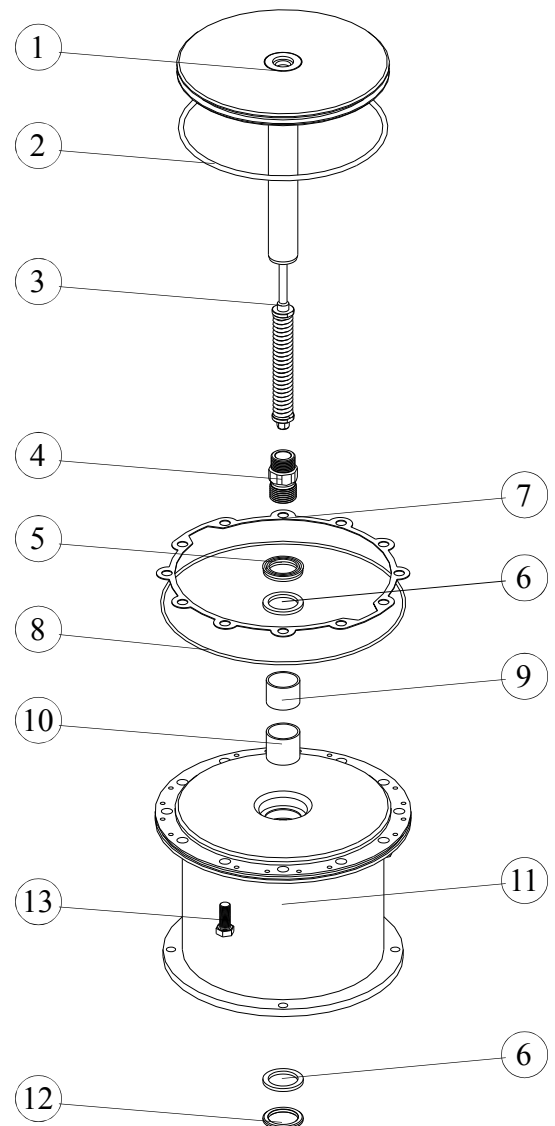

(fig. 2)

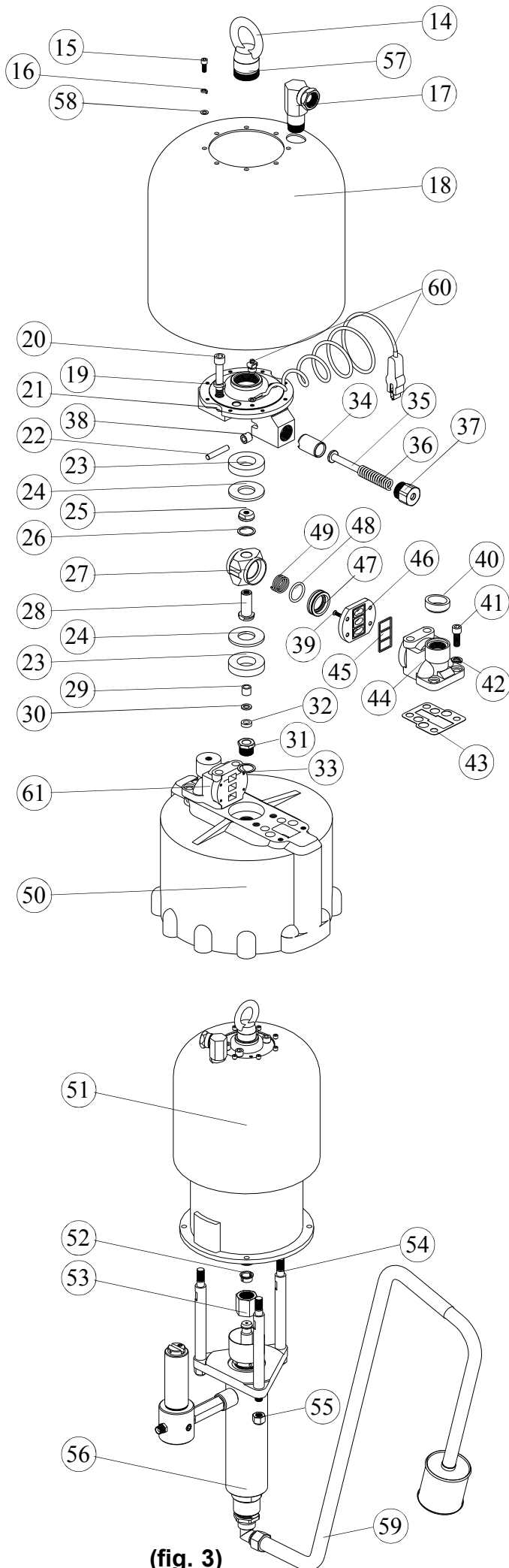

(fig. 3)

N°	REF.	DESCRIPTION	Q
14	CTU.141	EYRE	1
15	CTT.006	SCREW	8
16	CTT.007	SPRING WASHER	8
17	A.440.00	AIR INLET RACOR	1
18	A.400.01	HOUSING	1
19	CTT.005	SPRING WASHER	4
20	CTT.004	SCREW	4
21	A.410.08	SUPPORT	1
22	CPA.213	PIN	2
23	A.410.02	JOINT	2
24	A.410.03	SEAT	2
25	A.410.18	NUT	1
26	CAR.053	SPRING WASHER	1
27	A.410.17	AIR VALVE HOUSING	1
28	A.410.19	HUB	1
29	A.411.03	SLEEVE	1
30	A.411.04	JOINT	1
31	A.411.01	CONNECTOR	1
32	CAB.007	PACKING	1
33	CAR.012	JOINT	1
34	A.410.10	PLUNGER	2
35	A.410.12	SPRING DETENT	2
36	A.410.11	SPRING	2
37	A.410.13	SPRING RETAINER	2
38	A.410.09	ROLLER	2
39	CTT.002	SCREW	8
40	A.400.02	JOINT	1
41	CTT.001	SCREW	4
42	CTT.003	SPRING WASHER	4
43	A.410.04	JOINT	2
*44	*A.410.05A	VALVE BODY	1
45	A.410.07	JOINT	2
46	A.410.06	VALVE SEAT	2
47	A.410.15	VALVE	2
48	CJT.001	O-RING	2
49	A.410.16	SPRING	2
50	A.410.01	CYLINDER	1
51	A.400.00	AIR-MOTOR	1
52	C.410.01	SLEEVE	2
53	C.410.02	NUT	1
54	C.500.01	SPACER	3
55	CTT.009	NUT	3
56	B.500.00	DISPLACEMENT ASSY.	1
57	A.410.14	SPRING	1
58	CAR.021	WASHER	8
59	D.500.00	SUCTION KIT	1
60	TIE.GR	GROUND	1
*61	*A.410.05B	VALVE BODY	1

44.-* Valve body threaded

61.-* Valve body without thread

DISPLACEMENT PUMP

N°	REF.	DESCRIPTION	Q
1	B.520.00	PACKING NUT	1
*2	B.540.01	FEMALE GLAND	2
*3T	B.540.02T	PACKING	6
*3C	B.540.02C	PACKING	4
*4	B.540.03	MALE GLAND	2
5	B.510.00	HOUSING	1
6	B.500.01	PTFE JOINT	1
7	B.550.00	ROD	1
8	C.510.05	DISPLACEMENT ROD	1
9	B.500.02	SLEEVE	1
10	CBO.103	BALL	1
11	B.540.04	RETAINER	1
12	B.551.00	PISTON	1
13	CB0.115	BALL	1
14	B.560.03	BALL GUIDE	1
15	B.560.04	PIN	1
16	B.560.01	END RING	1
17	B.560.02	PTFE JOINT	1
18	B.561.00	INTAKE VALVE	1
19	G.100.02X	COVER	1
20	G.100.05	FILTER	1
21	G.100.04	SPRING	1
22	CTA.901	SCREW	1
23	G.500.03X	SUPPORT	1
24	G.100.07	JOINT	1
25	G.500.01X	BODY	1
26	G.500.04X	FITTING	1
27	104.600.14X	PLUG	2
28	G.500.05X	CONNECTOR	1
29	G.100.09X	PLUG	1

* Included in **KIT.010**

NOTE: Fix parts 7 and 12 with loctite 542 or similar (wait 1 hour before start running the unit)

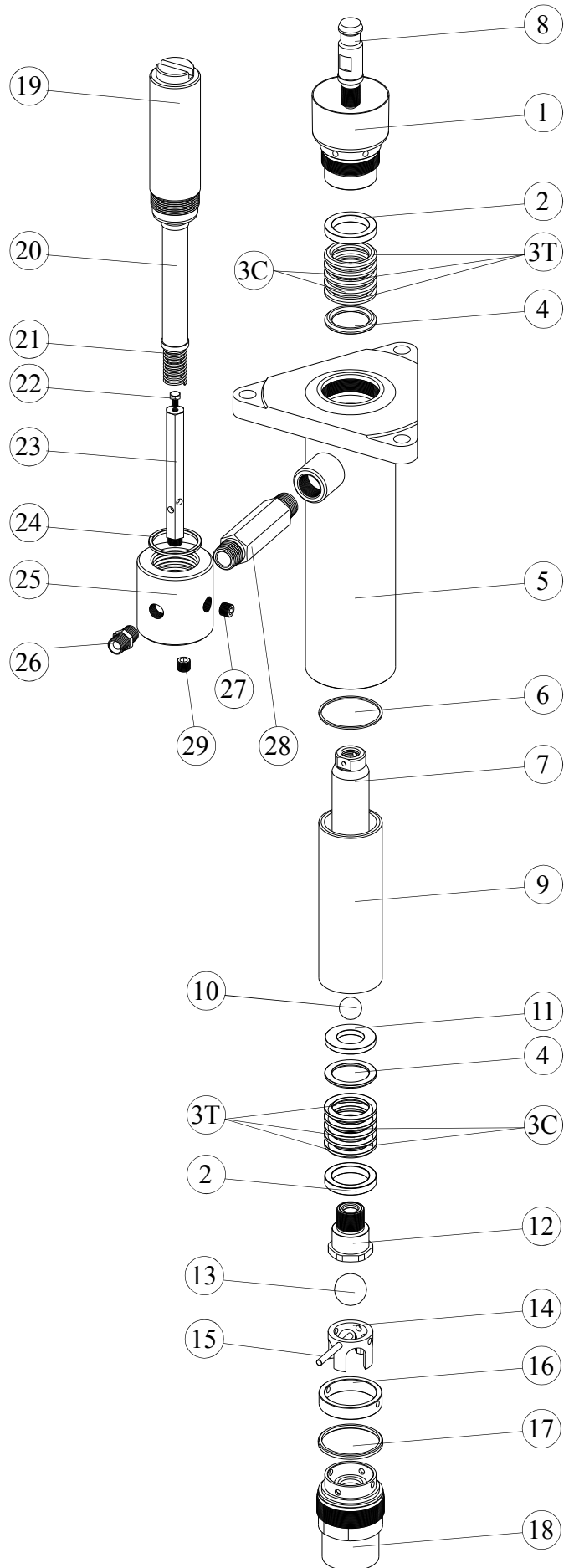

(fig. 4)

SERVICE HD-AIR MOTOR

Disconnect all hoses, rods, tubes, controls, etc. from the air motor as necessary to provide ease in servicing. Clamp the base (11) securely. Remove the union (17) and the eight screws (15), lockwashers (16) and washer (58). Remove the shield (18).

Refer to fig 5. Remove the detent spring retainers (37), springs (36), guides (35) and plungers (34). Inspect the parts for wear or damage, and replace parts as necessary.

CAUTION

Handle the springs carefully. Scratches or nicks will cause early failure.

Remove the four screws (20) and lockwashers (19) holding the detent housing (21) to the air manifolds. Don't drop the detent rollers (38); take them out of the housing and check the rollers and axles (22) for wear and damaged, replace both; they are a matched set. Remove the rubber pad (23) and washer (24), and check them carefully for damage.

Pull the valve housing (27) up, and remove the valves (47) and springs (49). Take the nut (25) and washer (26) off the trip rod (3). Pull the valve housing off the hub (31). Grip the trip rod below the housing hub (28) with a padded pliers, and screw the hub off the trip rod.

CAUTION

Take special care to avoid damaging the plated surface of the trip rod.

Remove the two mounting screws (41) of one manifold (44) only, and remove the manifold. Check the valve plates (46). When attaching a new valve plate to the manifold, be sure the mating surfaces of the plate and manifold are completely clean. Handle the plate carefully.

WARNING

The opening in the valve plates (46) are razor sharp. Be careful not to cut yourself when checking or handling them.

Remove the washer (24) and rubber pad (23) from the cylinder (50). Screw the trip rod bearing (31) out of the cylinder and carefully pull it up off the trip rod. Check the packing (32), washer (30) and gasket (29) and replace them if necessary. Grease the packings before installing in the cylinder.

Remove the twelve screws (13) holding the air cylinder (50) to the base (11). Pull the cylinder straight up off the piston. If the cylinder is stuck to the base, use a plastic hammer to break it loose. Be careful not to tilt the cylinder since this could damage the smooth inner surface. Check the piston o-ring (2) for wear or damage and replace if necessary.

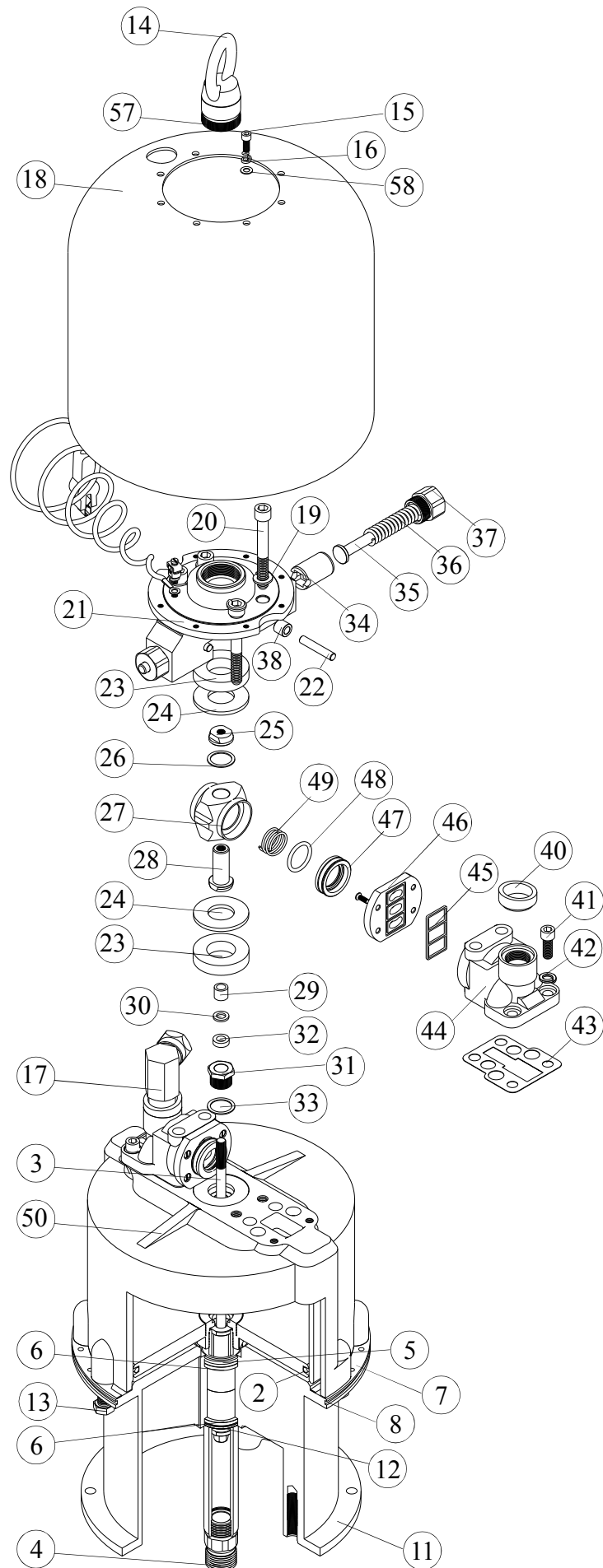

(fig. 5)

Also check if join (7) and o-ring (8) are in good condition, replace them if necessary.

See fig.6. Lift the piston and tube (1) from the base. Inspect the v-block throat packing (5) and back-up washer (6) in place. If replacement is necessary, remove the old packing and back-up washer, and carefully tuck a new back-up washer and packing into the throat cavity. The lips of the v-packing must face up towards the piston. Pack light, water-proof grease into the cavity above the wiper seal (12) and thoroughly lubricate the packing before reassembling.

CAUTION

Handle the trip rod and spring carefully. The spring surface must be free of nicks or scratches.

To inspect or replace the trip rod (3), clamp the flats (E) of the piston (1) in a vise and unscrew the stud (4) from the piston tube. Don't damage the polished surface of the tube.

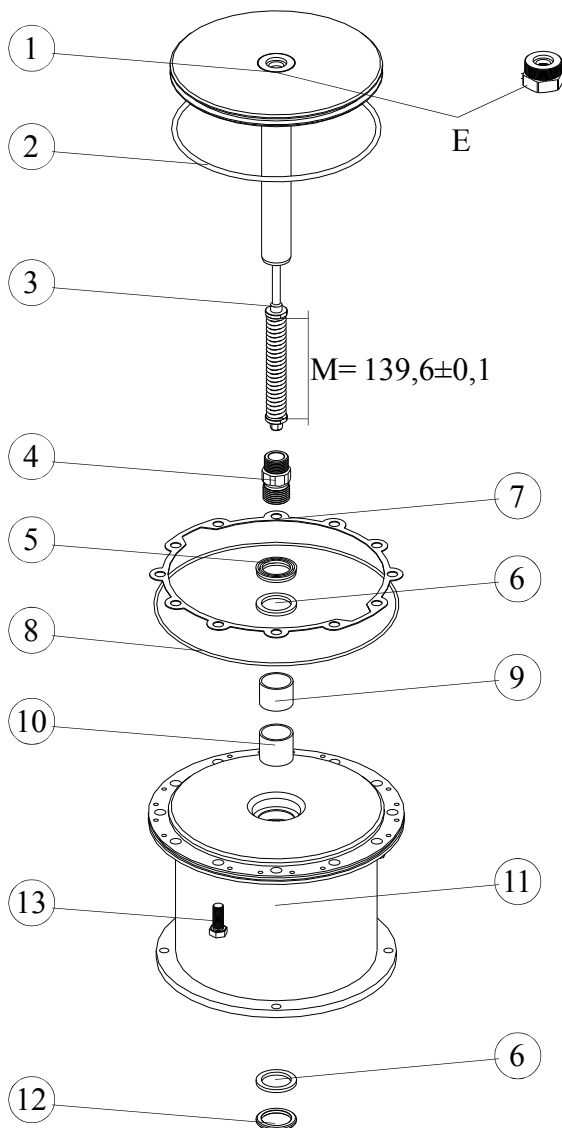

(fig. 6)

Whenever the trip rod (3) is removed from the piston tube (1) or a new trip rod is being installed, check to make sure the distance between the inside shoulders of the spring guides (M) is exactly 139,6 mm. See fig.6.

If the spring guide (M) is removed or the setting is not exactly 139,6 mm, or if any part of the trip rod is damaged, the entire trip rod assembly (3) must be replaced.

CAUTION

Do not attempt to readjust the spring guides (M). Readjustment could cause air motor failure.

Lubricate the spring and guides with light waterproof grease. Pack the grease into the cavity tube of the air piston (1). Use thread sealer on the threads of the stud (4) and torque to a minimum of 203 N.m (150 ft-lb).

Before installing the air cylinder (50), check to see that the gasket (7) and o-ring (8) are in place and the trip rod bearing (31) is removed from the cylinder top. Carefully place the cylinder (50) over the piston (1).

CAUTION

Do not tilt or force the cylinder since this could damage the smooth inner cylinder wall.

Be sure the floating o-ring seal is in place before bolting the cylinder (50) to the base (11). Be sure the air inlet is in line with the fluid outlet.

Using thread sealer, install the twelve screws (13) in the base. Torque the screws to 27-33 N.m (20-25 ft-lb). Install the gasket (29) on the trip rod bearing. Carefully twist the bearing down over the trip rod and tighten it securely into the cylinder. Place the rubber pad (23) and washer (24) into the cylinder top.

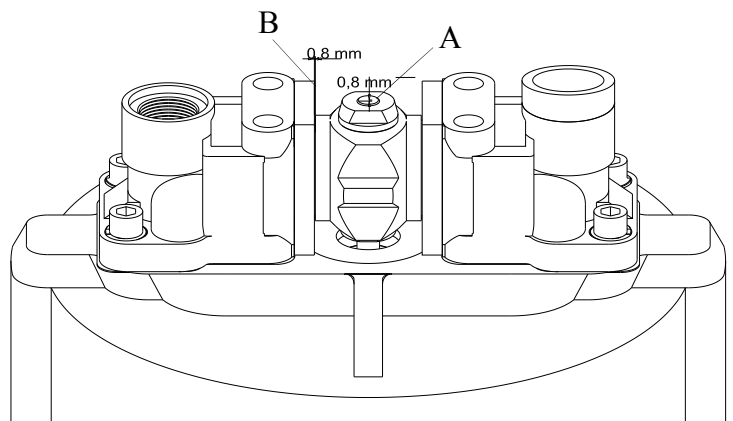

(fig. 7)

Grease and install the valve housing hub (28), housing (27), lockwasher (26) and nut (25) on the trip rod. Adjust the hub and nut until 0.8 mm, of the rod projects, then lock it in place by torquing the bearing (32) to 19-24 N.m (14-18 ft-lb). See Ref A, fig.7 .

Place the springs (49) and air valve rings (47), with the o-rings (48) installed, into the valve housing (27). Install the air manifolds (44) and gasket (43) into the cylinder. Be sure the air manifolds are properly aligned and spaced. Operating clearance must not be more that 0.8 mm. See ref. B, fig.7 on page 8. Check to be sure the housing moves up and down freely. Then tighten the shorter screws (41) holding the manifold to the cylinder.

Replace the washer (24) and pad (23). Before installing the detent housing (21), grease the detent rollers (38) and plungers (34) and place them into the housing. Line up the roller axles with the plunger slots. The grease will hold the parts in place while installing the guides (35), springs (36), and retainers (37).

Install the remaining air motor parts in the reverse order of disassembly. Connect the air motor to the displacement pump. Remount the pump and connect the air and fluid lines.

If the grounding wire was disconnected before servicing, be sure to reconnect it before operating the pump.

DISPLACEMENT PUMP REPAIR

- 1.- Solvent flush the pump, if possible. Follow the pressure relief procedure on page 3, stopping the pump at the bottom of its stroke. Then disconnect all hoses from the pump.
- 2.- Screw the intake valve housing (21) out of the pump housing (6). See fig 9. Disassemble and clean the parts of the valve.

NOTE: If your pump mounting provides enough clearance, you may not have to remove the entire pump from its mounting to remove and service the displacement pump: just follow step 3. If it is necessary to remove the entire pump from its mounting, clamp it in a vise before removing the displacement pump.
- 3.- Loosen the packing nut (7). Loosen the nut (4). Remove the three tie rod locknuts (5). Pull the displacement pump down off the motor.
- 4.- Push down on the displacement rod (12) until the piston (16) flats clear the pump housing (6). Pull the piston and displacement rod assembly out of the pump housing.
- 5.- Unscrew the piston, and remove the ball, washer, v-packings and glands.

- 6.- Remove the packing nut wet-cup (7). Remove the v-packing and glands from the throat of the pump housing.
- 7.- Clean all parts thoroughly, and check for wear, scratches or other damage. Scoring or irregular surfaces on the displacement rod (12) or polished inner wall of the sleeve (13) can cause premature packing wear and leaking. Check these parts by rubbing a finger on the surfaces or by holding the parts up to the light at an angle. If either is worn or scratched, replace it. Be sure the ball seats of the piston (16) and intake valve housing (21) are not chipped or nicked. Replace any worn or damaged parts to ensure that the pump will not leak.
- 8.- Lubricate the packings and displacement rod with a lightweight grease for easier assembly.
- 9.- Install one of the repair kit's packing stacks in the throat of the pump housing. Be sure the lips of the v-packings face down in the throat. (See fig. 10)
- 10.- Loosely install the packing nut/wet-cup (7).
- 11.- Install the repair kit's other packing stack on the piston (16). Be sure the lips of the v-packings face up on the piston. (See fig. 11)
- 12.- Place the ball (14) on the piston , and screw the piston assembly into the displacement rod (12), torquing to (203-237 N.m).Use thread sealer (loctite 542) on the piston thread.
- 13.- Lubricate the displacement rod again, and guide it through the bottom of the pump housing and carefully through the throat packings.
- 14.- Install the o-ring (20) on the intake valve housing (21). Install the ball (17), ball guide (19), retainer (12), and ball stop pin (18) in the intake valve housing. Be sure the pin is in the desired set of holes. Refer to check valve adjustment, below. Screw the assembly firmly into the pump housing.
- 15.- Screw the displacement rod (12) onto the connecting rod (2). Tighten the nut (4). Align the tie rods with the pump motor (1), and install the tie rod locknuts (5) loosely.
- 16.- Start the pump, and run it a its lowest speed posible, about 2 bar, while you tighten the tie rod locknuts (5) evenly to 47-68 N.m. Adjust the tie rod locknuts, if necessary, to eliminate binding.
- 17.- Tighten the packing nut just enough to prevent leakage, but no tighter. Use the bars supplied with the complete pump. Fill the wet-cup half full with oil or compatible solvent.

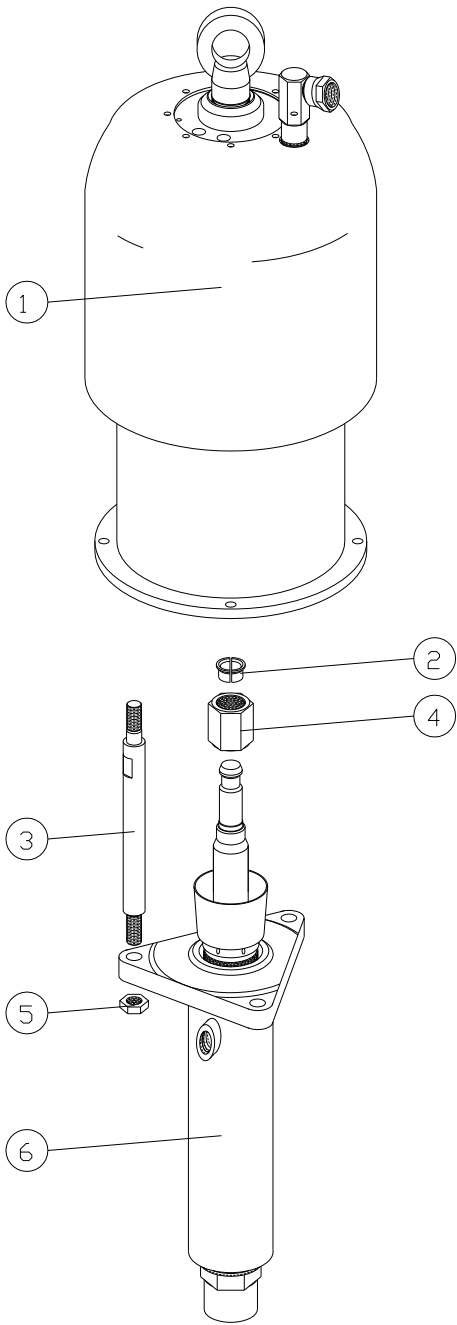

(fig. 8)

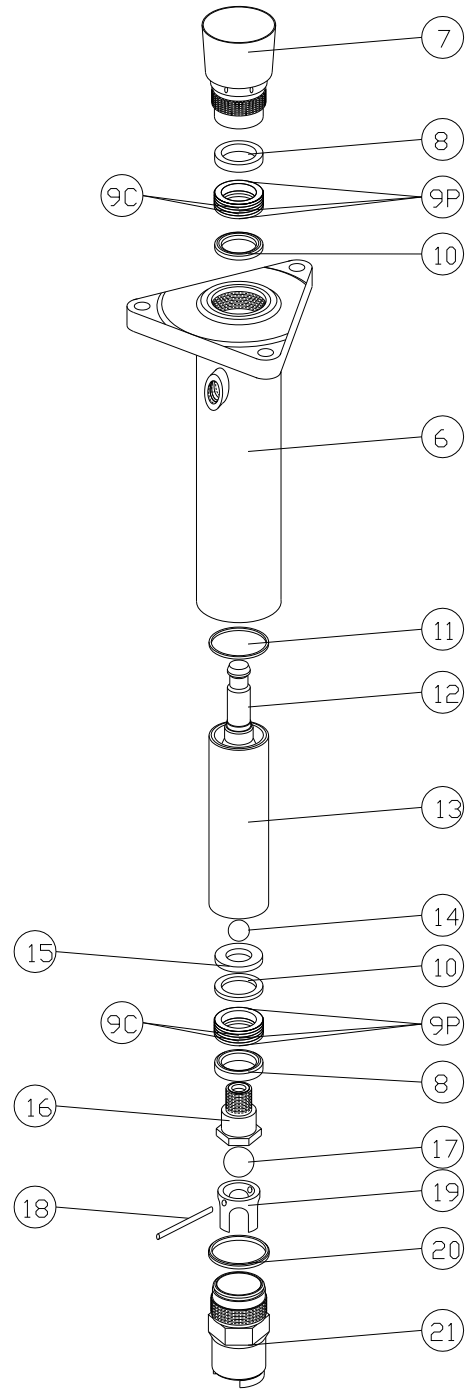

(fig. 9)

NOTE:

If the ground wire was disconnected before servicing, be sure to reconnect it before operating the pump, and check to be sure the entire system is properly grounded.

Check valve adjustment.

The intake valve housing (21) is set for high flow rates or high viscosity fluids. To set the valve for lighter viscosity fluids or a lower flow rate, to minimize surging at pump stroke changeover, move the ball stop pin (18) to the lower set of holes, decreasing the check ball travel. The piston check valve in this pump is not adjustable.

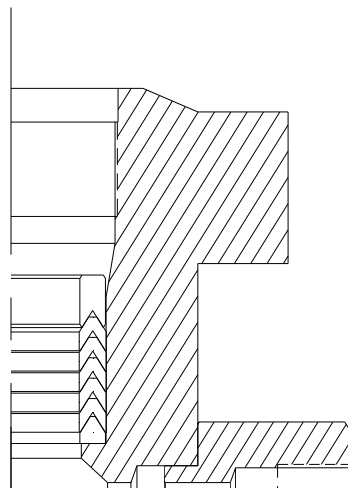

(fig. 10)

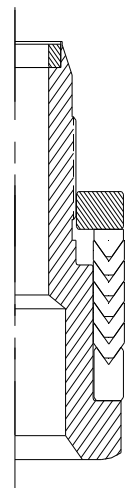

(fig. 11)

TROUBLESHOOTING GUIDE

PROBLEM	POSSIBLE CAUSE	SOLUTION
Pump. fails to operate.	<ul style="list-style-type: none"> ■ Restricted line or inadequate air supply. ■ Insufficient air pressure, closed or clogged air valves, etc. ■ Exhausted fluid supply. ■ Obstructed fluid hose, gun or dispensing valve. ■ Clogged spray tip or filters. 	<ul style="list-style-type: none"> ■ Clear, increase air. ■ Open, clean. ■ Refill; purge all air from pump and fluid lines. ■ Clear. ■ Clear or replace.
Pump operates but output low on down stroke.	<ul style="list-style-type: none"> ■ Clogged filters. ■ Throat packings nut too tight or too loose. ■ Exhausted fluid supply. ■ Obstructed fluid hose or gun. ■ Worn spray tip. ■ Held open or worn intake valve. ■ Held open or worn fluid piston or packings. 	<ul style="list-style-type: none"> ■ Clear or replace. ■ Adjust. ■ Refill and prime. ■ Clear. ■ Replace. ■ Clear. ■ Clear or replace.
Erratic or accelerated operating.	<ul style="list-style-type: none"> ■ Exhausted fluid supply. ■ Check valves need adjustment. ■ Held open or worn intake valve. ■ Held open or worn fluid piston or packings. 	<ul style="list-style-type: none"> ■ Refill and prime. ■ Adjust. ■ Clear. ■ Clear or replace.

For trouble free operation is absolutely essential that your sprayer be kept clean and free of residual paint build-up on the internal parts. It must be cleaned and lubricated after each use.

TECHNICAL DATA

PUMP RATIO: 45:1.

RECOMMENDED MAXIMUM AIR SPEED: 50 CYCLES/MIN.

RECOMMENDED AIR PRESSURE: FROM 2 TO 6,5 BAR.

FLOW AT 60 CYCLES/ MIN.: 15,67 LITRES/MIN.

MAXIMUM WORKING PRESSURE: 292 BAR.

STANDARD SPRAY TIPS

ORIFICE SIZE MM / INCHES	FLOW IN LITRES / MIN	FAN WIDTH AT 300 MM.	ORIFICE SIZE MM / INCHES	FLOW IN LITRES / MIN	FAN WIDTH AT 300 MM.
0.23 MM. .009" 9.20 9.40 9.60	0.30	100-150 200-250 300-350	0.53 MM. .021" 21.20 21.40 21.60	1.74	100-150 200-250 300-350
0.28 MM. .011" 11.20 11.40 11.60	0.45	100-150 200-250 300-350	0.58 MM. .023" 23.20 23.40 23.60	2.08	100-150 200-250 300-350
0.33 MM. .013" 13.20 13.40 13.60	0.64	100-150 200-250 300-350	0.63 MM. .025" 25.20 25.40 25.60	2.49	100-150 200-250 300-350
0.38 MM. .015" 15.20 15.40 15.60	0.87	100-150 200-250 300-350	0.68 MM. .027" 27.20 27.40 27.60	2.91	100-150 200-250 300-350
0.43 MM. .017" 17.20 17.40 17.60	1.13	100-150 200-250 300-350	0.74 MM. .029" 29.20 29.40 29.60	3.33	100-150 200-250 300-350
0.48 MM. .019" 19.20 19.40 19.60	1.36	100-150 200-250 300-350	0.79 MM. .031" 31.20 31.40 31.60	3.86	100-150 200-250 300-350

WARRANTY

M.B.P., will any repairs necessary during the first 12 months after purchase of a new unit, with the exceptions shown under 1 and 2 below, and under the conditions shown in item 3.

- 1.- Damage caused by external abuse, customer negligence, or failure to operate the unit in accordance with the instructions supplied with the unit.
- 2.- Normal maintenance items.
- 3.- Within the first 12 months after purchase, M.B.P. will pay 100% of the cost of covered repairs.

In no case will M.B.P. liability extend beyond repair or replacement of the equipment. Such liability is limited to the amount of the original purchase price paid for the unit, minus a reasonable deduction for the time the unit has been in service. It is the responsibility of the purchaser under this warranty to ship or deliver the failed paint sprayer to the authorized service center at the purchaser's expense. Parts or components covered under this warranty may either be repaired or replaced at M.B.P. option.

Equipment not covered by M.B.P. warranty. Accessories or components of equipment sold by M.B.P. that are not manufactured by M.B.P. are subject to the warranty, if any, of their manufacturer. M.B.P. will provide purchaser with reasonable assistance in making such claims.

The Industry Department of The Basque Government, states that all electric and pneumatic airless equipment manufacture by M.B.P. S.L., follows the "CE" standards under the number 83/392/CEE.

DECLARACION DE CONFORMIDAD "CE" "EC" DECLARATION OF CONFORMITY

MODELO / MODEL HD - 45 INOX

Este producto cumple con la siguiente directiva de la Comunidad Europea.

This Product complies with the following European Community Directive.

Directiva 2014/34/EU Atex sobre máquinas. (Ex II 2G c T6 X)

Machinery Directive 2014/34/EU Atex Directive. (Ex II 2G c T6 X)

APROBADO POR /

APPROVED BY

AITOR ORTIZ

FECHA / DATE

MBP, S.L. figura inscrita en el Registro Industrial del País Vasco con el N° 01/8030 y cumple los requisitos para el desarrollo de su actividad comercial.

MBP, S.L. is registered in the Industrial Register of the Basque Country with the N° 01/8030.

